



Standard-Duty Slide

FEATURES:

- 30 x 175 mm (1.2 x 6.9 in) base plate
- Home reference switch and far end limit switch with ± 0.01 mm (± 0.0004 in) repeatability
- Aluminum dust cover with plastic lip seals to protect against contaminants
- Features 2 patented double linear rails and 4 patented double bearing blocks
- All models with stepper motor option feature 88 N-cm (125 oz-in) stepper motor, model HL2600M210001
- All models with 200W servomotor option feature motor model HZ2600M1050XY3 with line driver optical rotary encoder, 1000 line, 100W servomotor uses HZ2600M0243600-L
- Standard antbacklash ball screw and nut, 16 mm (.6 in) diameter with 5 mm (.2 in) pitch for play-free, precise motion
- Work surface is flat milled aluminum 220 x 175 x 8 mm (8.7 x 6.9 x .3 in) with 8 drilled and tapped M6 mounting holes
- Optional ball screw is 16 mm (.6 in) diameter, 10 mm (.4 in) or 20 mm (.8 in) pitch
- Can be ordered with motor mounted inline or side-mounted

Side Mount with Servomotor

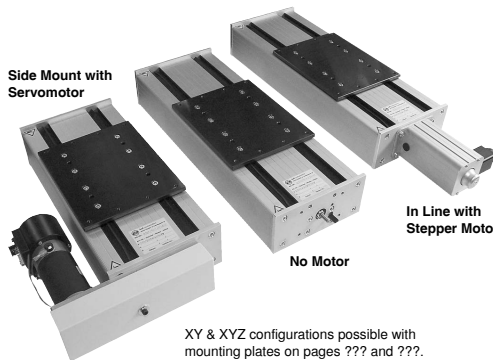

In Line with Stepper Motor

No Motor

XY & XYZ configurations possible with mounting plates on pages ??? and ???.

CATALOG NUMBER

HL31 M601

Motor Drive

- X** No Motor
- V** Servomotor (200W)
- B** Stepper Motor (200W) w/ 24V DC Brake
- L** Servomotor (100W)
- M** Servomotor (100W) w/ 24V DC Brake
- S** Stepper motor
- A** Stepper motor w/ 24V DC Brake
- C** Crank Handle

Screw Type

- B** Ball Screw
- K** Ball Screw w/ Side Mount Motor

Code
0300
0400
0500
0600
0850
1000
1100
1250
1350
1500

Screw Pitch

- 05** 5 mm (.2 in)
- 10** 10 mm (.4 in)
- 20** 20 mm (.8 in)

STANDARD-DUTY SLIDE SELECTION

Code	L1 Length mm (in)	Travel mm (in)	Weight kg (lb)
0300	300 (11.8)	57 (2.2)	7.3 (16)
0400	400 (15.7)	157 (6.2)	9.5 (21)
0500	500 (19.7)	257 (10.1)	11.8 (26)
0600	600 (23.6)	357 (14.1)	13.6 (30)
0850	850 (33.5)	607 (23.9)	19 (42)
1000	1000 (39.4)	757 (29.8)	20 (44)
1100	1100 (43.3)	857 (33.7)	22.2 (49)
1250	1250 (49.2)	1007 (39.6)	25 (55)
1350	1350 (53.1)	1103 (43.4)	27.2 (60)
1500	1500 (59.1)	1257 (49.5)	30 (66)

EXAMPLE: To order a Standard-Duty Slide with Stepper Motor (**S**), 5 mm (.2 in) Pitch Ball Screw (**B**) & 157 mm (6.2 in) Travel (**0400**), the Catalog Number is **HL31SBM601040005**.

For mating connectors, cables, motor standoffs, and couplings see the accessories section.



Standard-Duty Slide

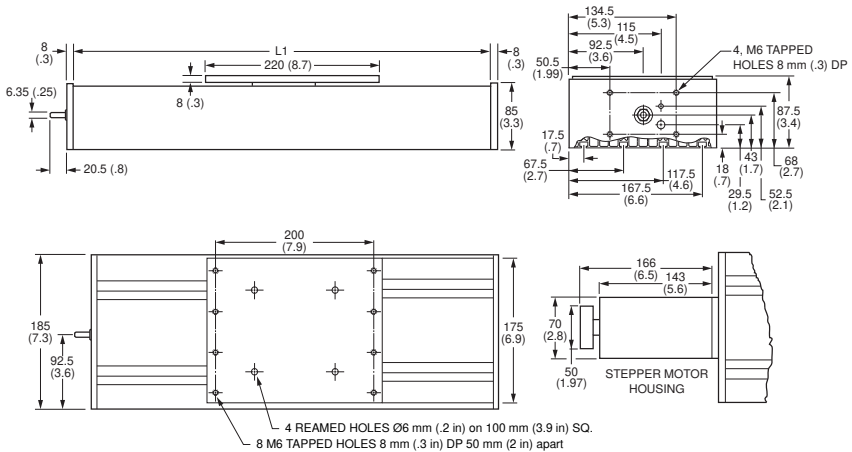

(See Web site for complete CAD drawings)

SPECIFICATIONS

Repeatability	± 0.01 mm (± .0004 in)
Accuracy	± 0.1 mm / 300 mm (± .004 in / 12 in)

Motor Drive	Ball Screw Pitch mm (in)	Thrust Force at Low Speeds, kg (lb)	No Load Speed mm/sec (in/sec)	Resolution mm (in)
Stepper Motor	5 (.2)	91 (200)	127 (5)	0.0125 (.0005)
	10 (.4)	45 (100)	254 (10)	0.025 (.001)
	20 (.8)	23 (50)	510 (20)	0.05 (.002)
200W Servomotor	5 (.2)	113 (250)	152 (6)	0.0025 (.0001)
	10 (.4)	57 (125)	305 (12)	0.005 (.0002)
	20 (.8)	28 (63)	610 (24)	0.01 (.0004)

For notes on specifications to produce this data, refer to page xxx.

LOAD and MOMENT DATA

Model	Standard-Duty Slide
F1 Stat	3200 N (719.4 lbs)
F1 Dyn	1600 N (357.7 lbs)
F2 Stat	3200 N (719.4 lbs)
F2 Dyn	1600 N (357.7 lbs)
Mx Stat	79 N-m (700 lb-in)
Mx Dyn	56 N-m (500 lb-in)
My Stat	79 N-m (700 lb-in)
My Dyn	56 N-m (500 lb-in)
Mz Stat	79 N-m (700 lb-in)
Mz Dyn	56 N-m (500 lb-in)

